



PROJECT DESCRIPTION:

SHALLOW BOWL PLANTER
LSA2 25 1/2" dia x 7" tall

DRAWN BY:

V. TOSHANOVA

SCALE:

DATE:

APPROVED BY:

DWG NO:

REV DATE:

12665 116 Ave Surrey, BC V3V 3S6 Ph. 604-580-4108 toll free 800-671-8882 FAX. 604-580-411 info@sandersonconcrete.com

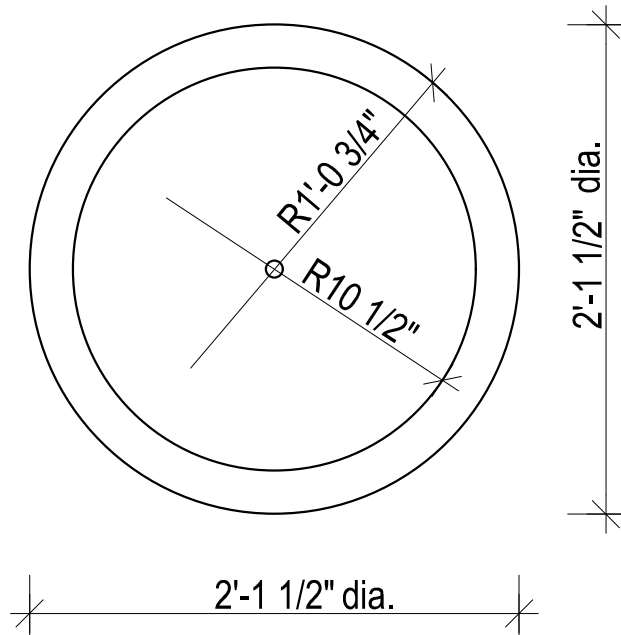
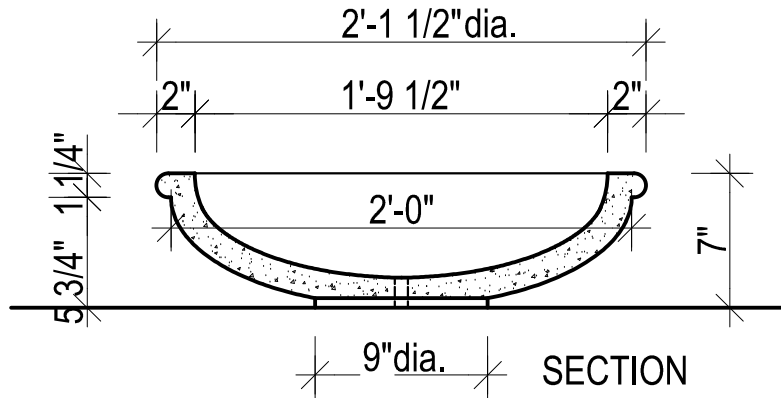

SHALLOW BOWL PLANTER	Diameter x Height	weight
LSA2	25 1/2" X 7"	85 lbs