



PROJECT DESCRIPTION:  
**TRAFFIC BOLLARD  
MATSQUI 24**

DRAWN BY:  
V. TOSHANOVA  
APPROVED BY:

SCALE:  
DATE:  
DWG NO:  
REV DATE:

12665 116 Ave Surrey, BC V3V 3S6 toll free 800-671-8882 FAX.604-580-411 info@sandersonconcrete.com

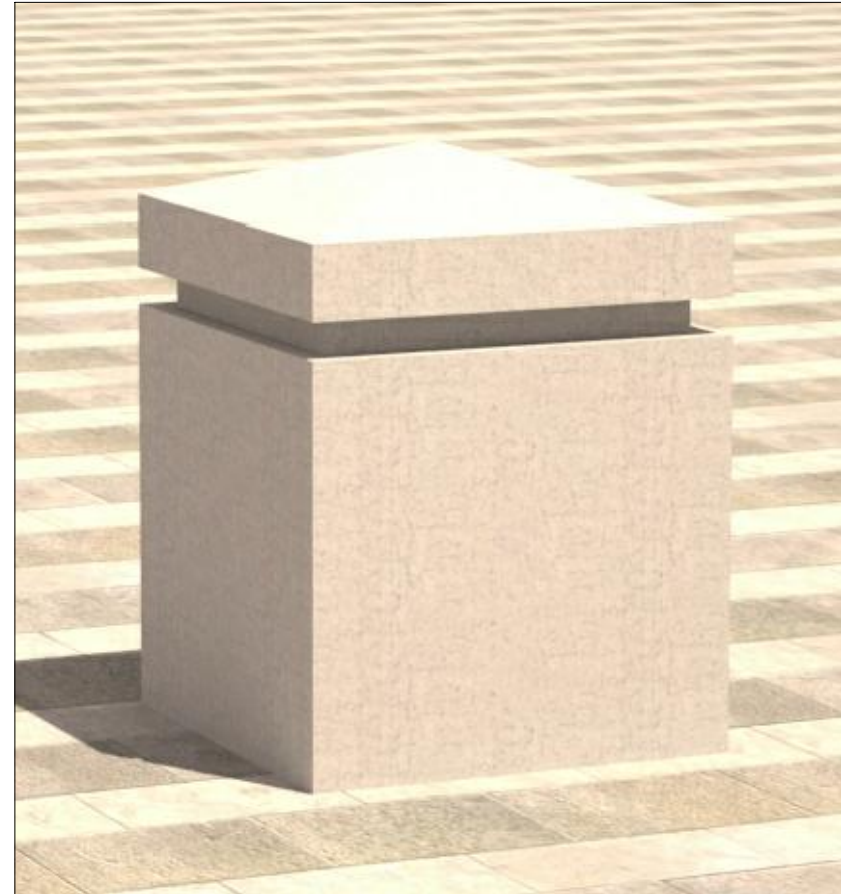
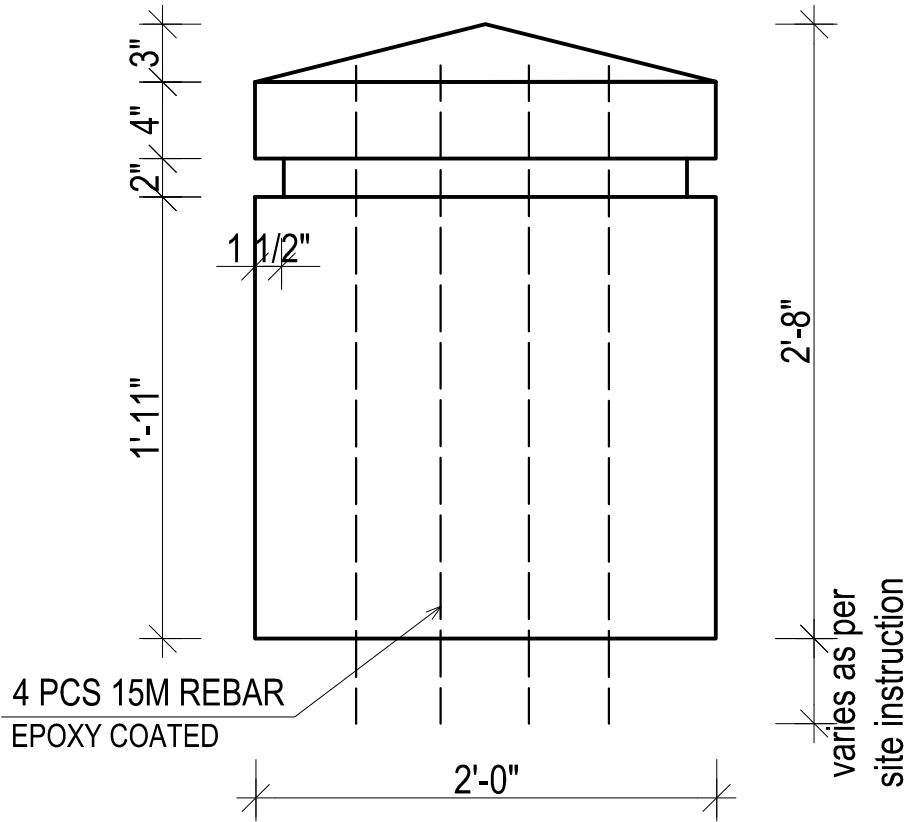

TRAFFIC BOLLARD MARTQUI 24	Diameter x Height	weight
	24" x 32"	1200 lbs