



PROJECT DESCRIPTION:
RECTANGULAR PLANTER
 RL19 19 1/2" x 13 1/2" X 12 tall

DRAWN BY:
 V. TOSHANOVA
 APPROVED BY:

SCALE:
 DATE:
 DWG NO:
 REV DATE:

12665 116 Ave Surrey, BC V3V 3S6 Ph. 604-580-4108 toll free 800-671-8882 FAX. 604-580-4111 info@sandersonconcrete.com

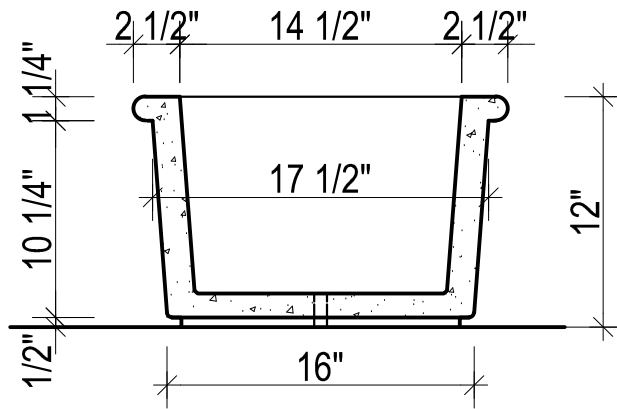

SECTION

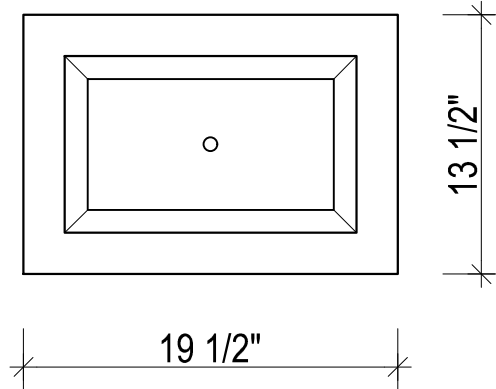

TOP VIEW

RECTANGULAR PLANTER RL19	Width x Length x Height	weight
	19 1/2" x 13 1/2" X 12"	65 lb.