



PROJECT DESCRIPTION:

RECTANGULAR PLANTER  
RL37 37 1/2" x 19 1/2" X 16 tall

DRAWN BY:

V. TOSHANOVA

APPROVED BY:

SCALE:

DATE:

DWG NO:

REV DATE:

12665 116 Ave Surrey, BC V3V 3S6 Ph. 604-580-4108 toll free 800-671-8882 FAX. 604-580-411 info@sandersonconcrete.com

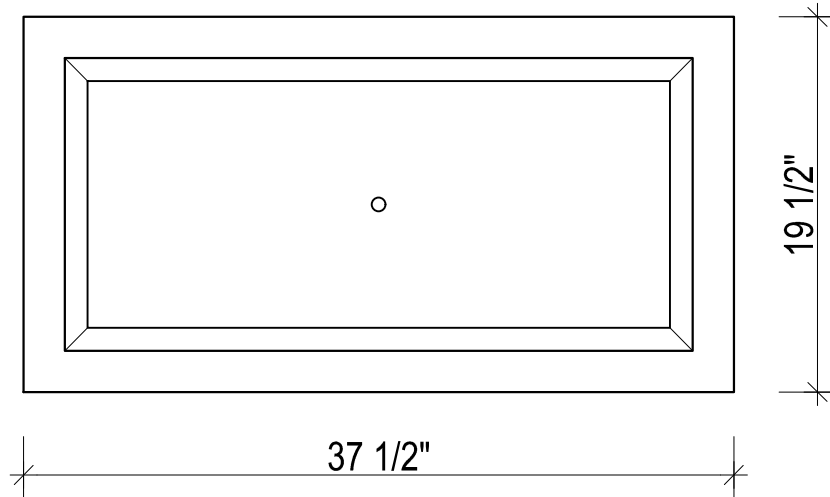
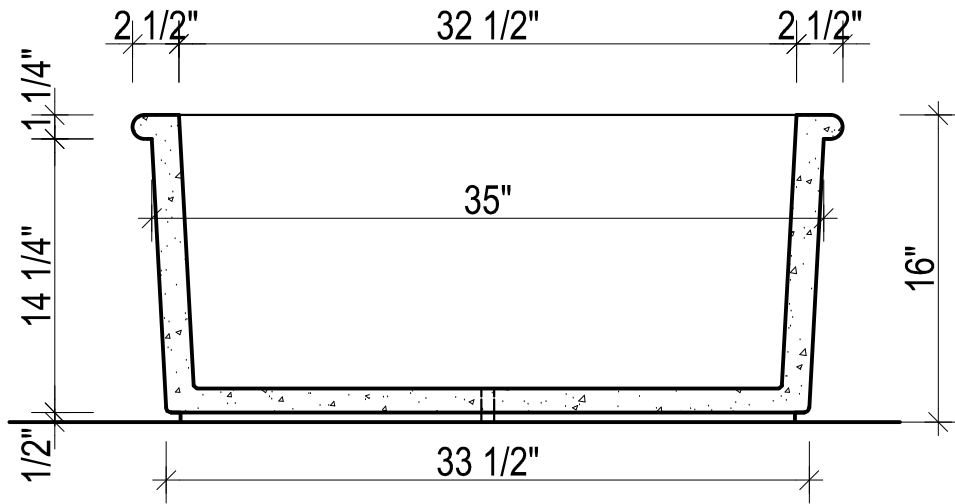

RECTANGULAR PLANTER	Width x Length x Height	weight
RL37/19	37 1/2" x 19 1/2" X 16"	300 lb.