

**ELEVATION**  
1 1/8" = 1'

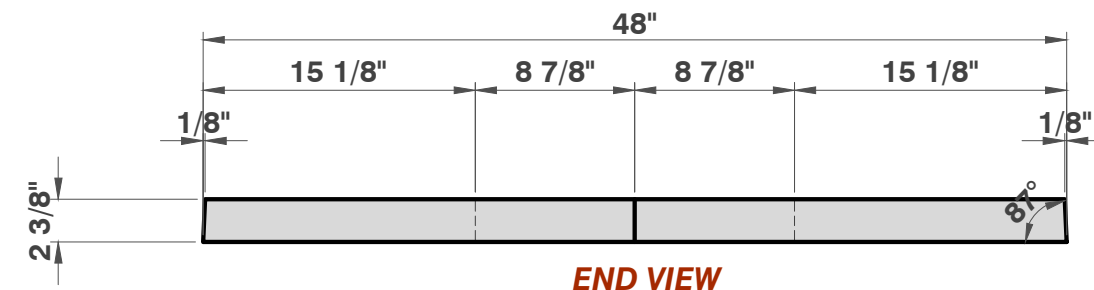

**END VIEW**  
1 1/8" = 1'

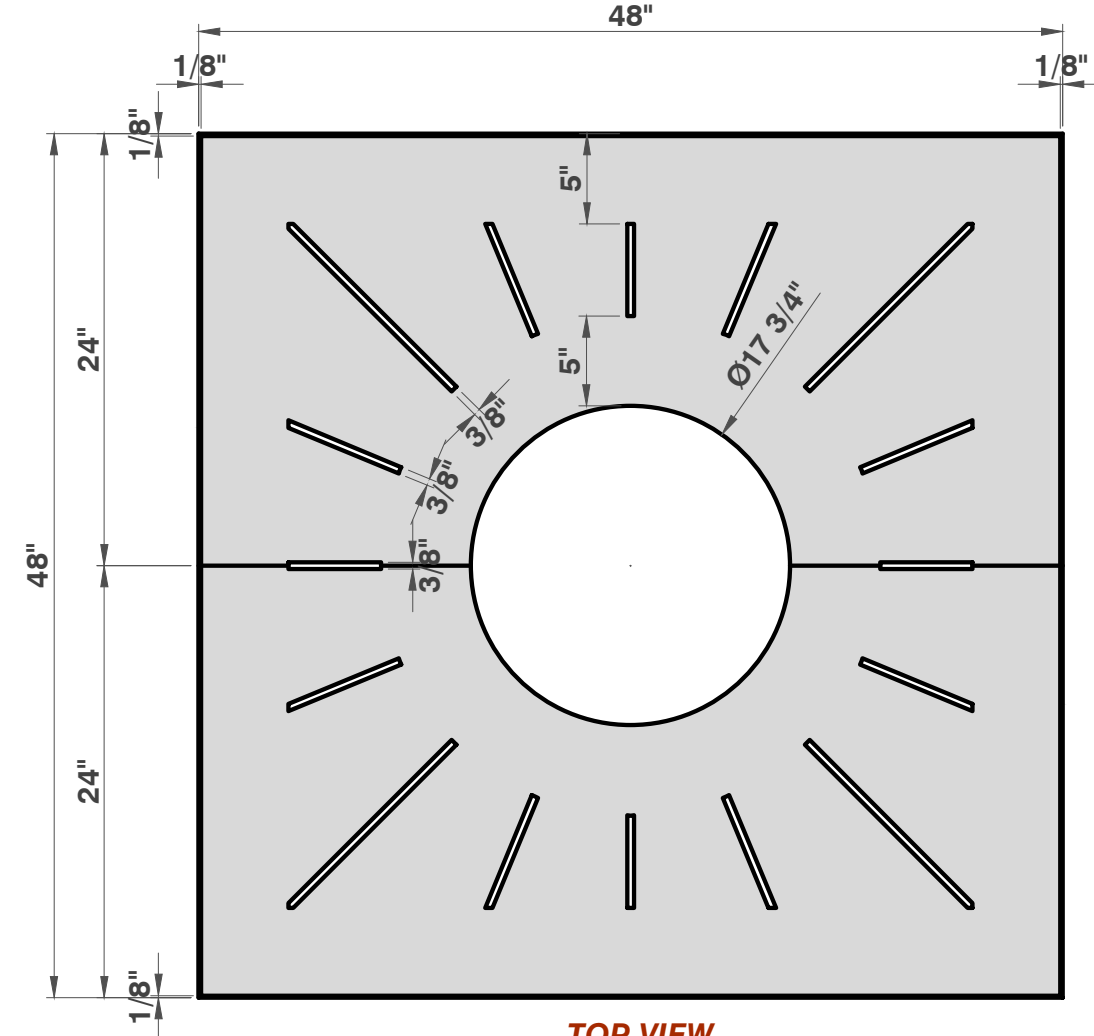

**TOP VIEW**  
1 1/8" = 1'

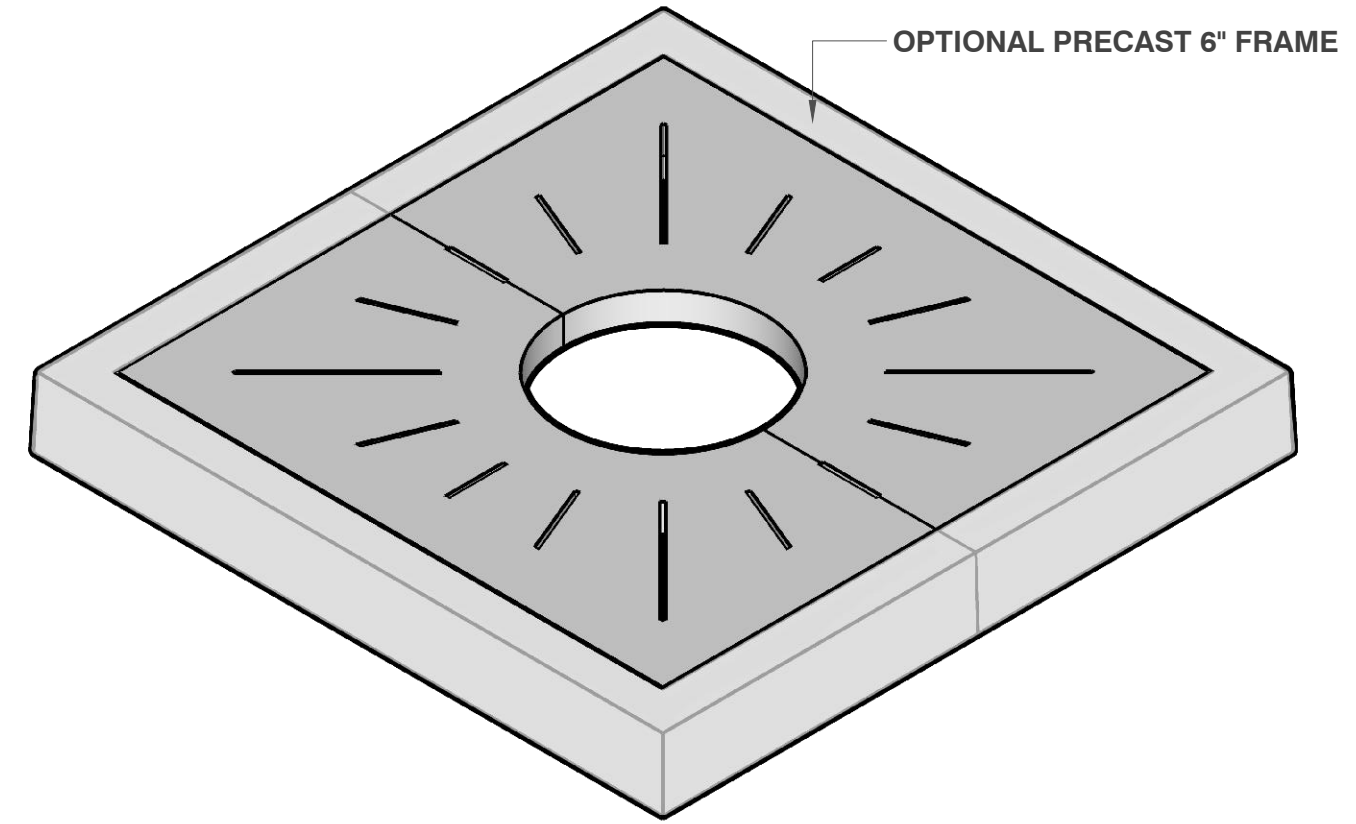

**3D DRAWING**

CUSTOMER DETAIL INFORMATION	
QUANTITY	
FINISH	PLAIN CONCRETE, DRY CAST PROCESS, SANDBLAST, EXPOSED AGGREGATE
COLOUR	CUSTOM COLOURED
WEIGHT (TOTAL)	268 LBS.
DIMENSIONS	48" x 48" x 2 3/8"



PROJECT DESCRIPTION:  
**48" TREE GRATE**

DRAWN BY: YJE  
REQD BY: JP  
APPROVED BY:

RN.	DESCRIPTION	MM/DD/YY	SCALE: AS SHOWN
			DATE: 10/20/21
			PAGE NO: 01

D:\SANDERSON CONCRETE INC\00190 - 101821 - 48inch Tree Grate -JP\01.ACAD\01.SET\48inch Tree Grate 10182021.dwg