

TOP VIEW
2"=1'

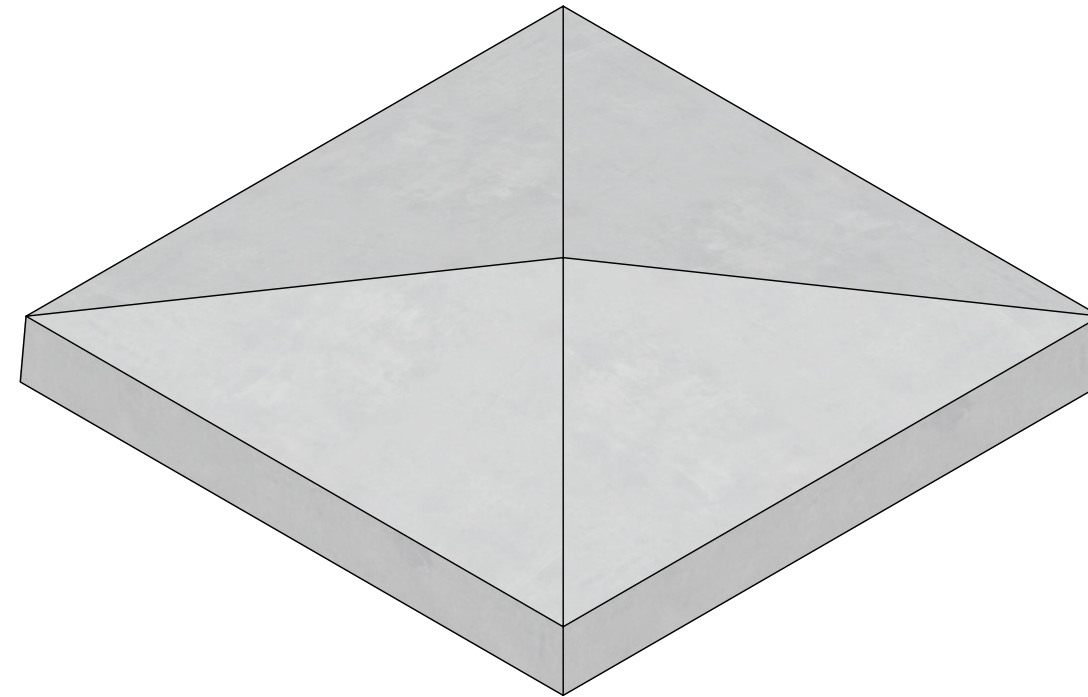

ISOMETRIC VIEW
2"=1'

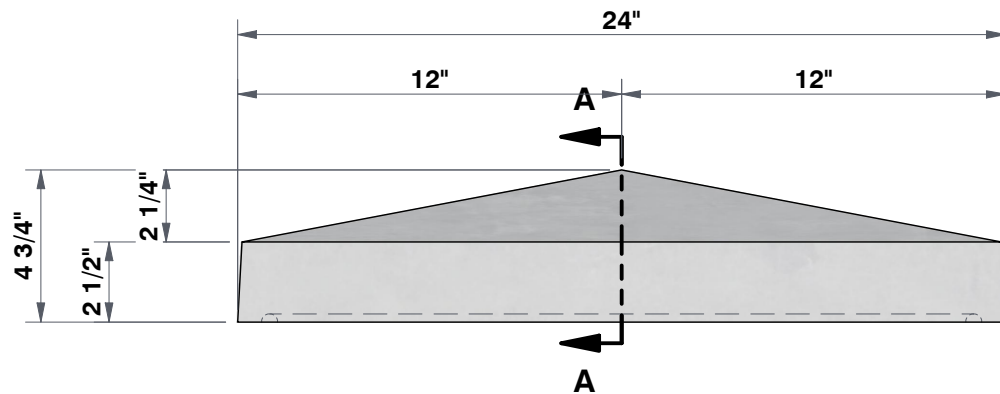

FRONT VIEW
2"=1'

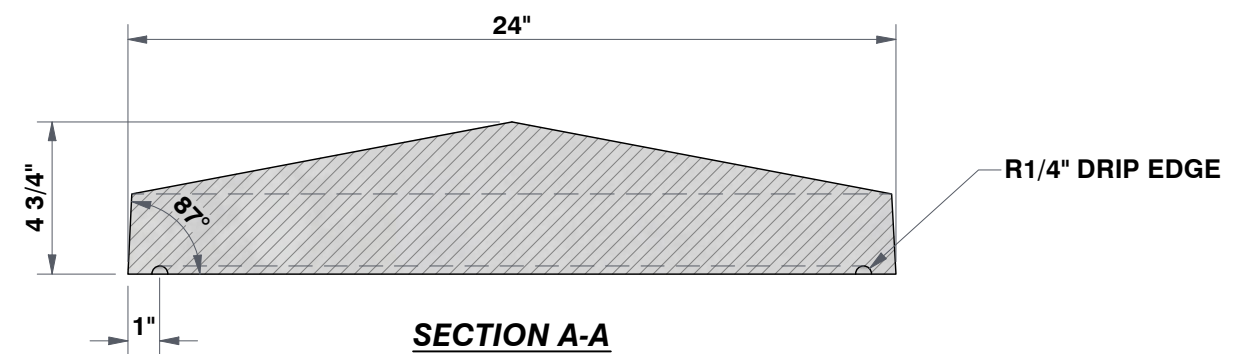

SECTION A-A
2"=1'

CUSTOMER DETAIL INFORMATION

QUANTITY	
FINISH	
COLOUR	
WEIGHT	164.9 LBS (74.8 KG)
DIMENSIONS	24" x 24" x 4 3/4"



PROJECT DESCRIPTION:

**PEAKED POST CAP
POST 24A**

DRAWN BY: **YJE**
REQD BY: **CA**

APPROVED BY:

SCALE: 2"=1'

DATE: 2023/7/24

SHEET NO:

1 - 1