

**TOP VIEW**  
1"=1'

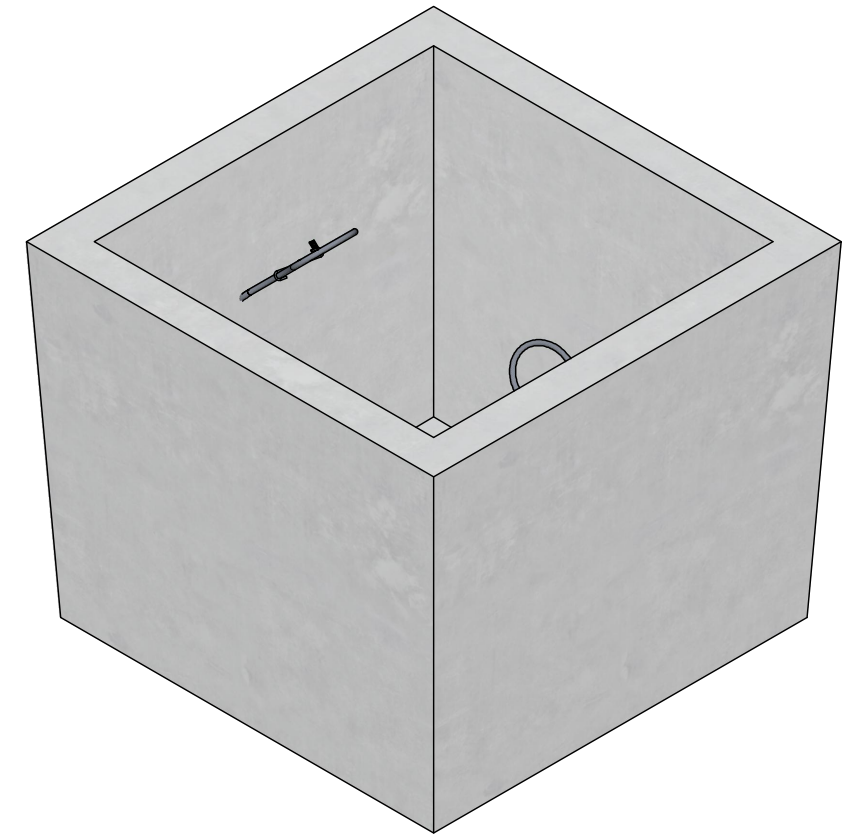

**ISOMETRIC VIEW**  
1"=1'

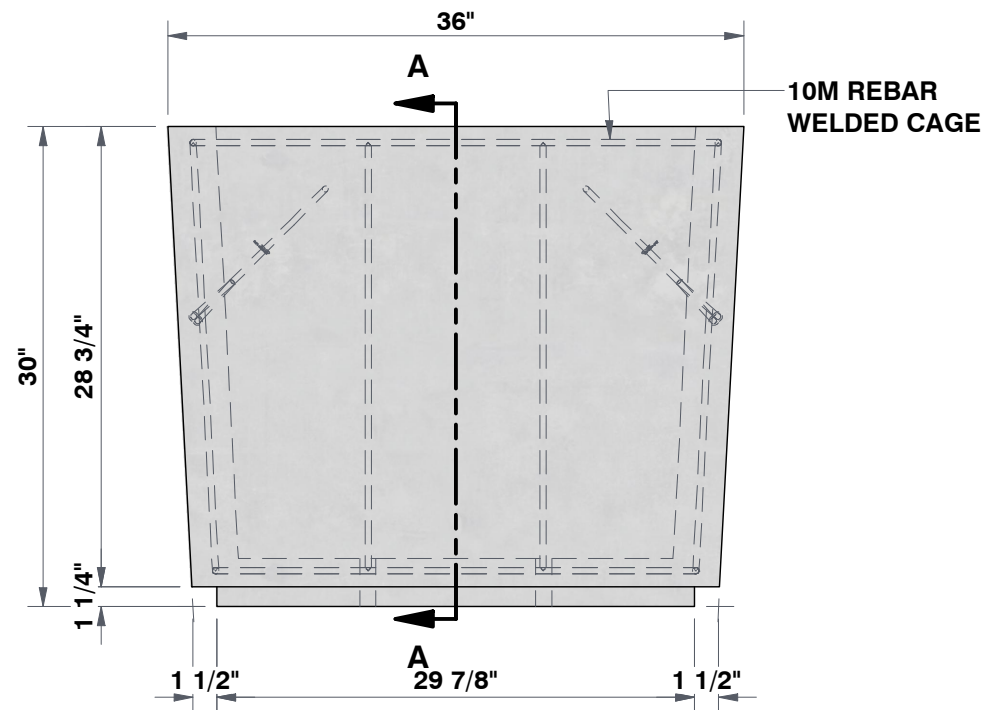

**FRONT VIEW**  
1"=1'

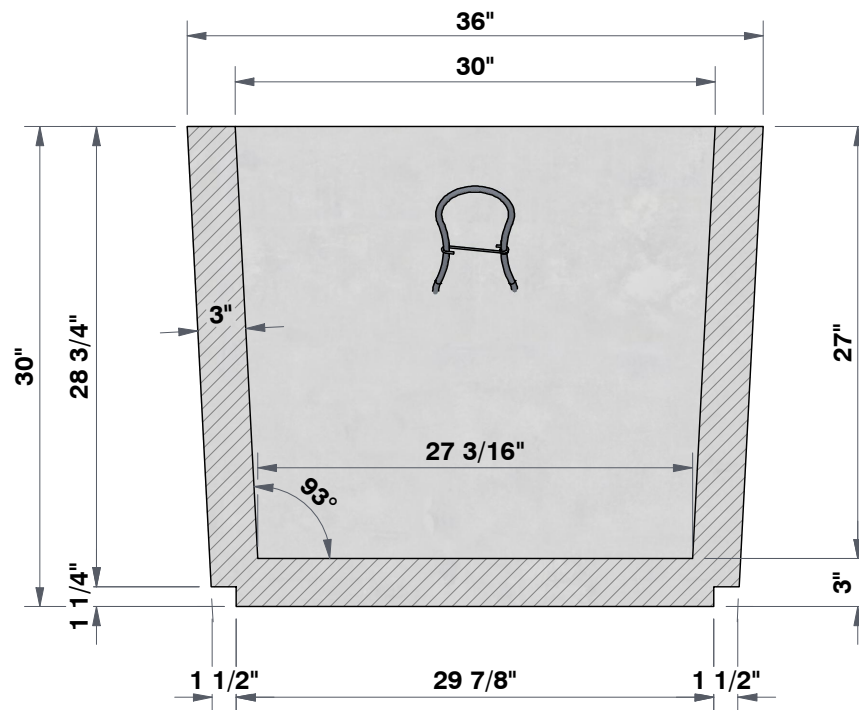

**SECTION A-A**  
1"=1'

**CUSTOMER DETAIL INFORMATION**

QUANTITY	
FINISH	
COLOUR	
WEIGHT	2172.41 LBS (985.4 KG)
DIMENSIONS	36" x 36" x 30"



**PROJECT DESCRIPTION:**

**SQUARE PLANTER  
S3630**

DRAWN BY: **YJE**  
REQD BY: **CA**

APPROVED BY:

SCALE: 1"=1'

DATE: 2023/8/1

SHEET NO:

1 - 1